

WA-840

Double Needle, Postbed Sewing Machine

雙針高頭車

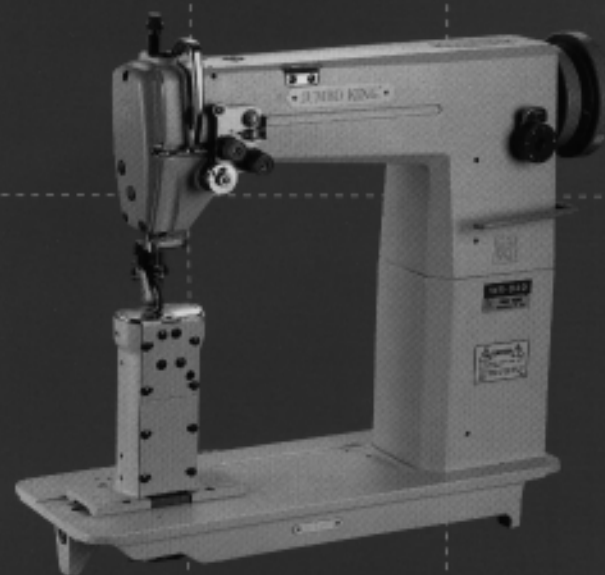

特點 / FEATURES

自小配件與細微材料之縫製迄由線形之縫紉,本機系統使您優越縫製技術威力充分發揮之高頭車。

採用全迴轉水平式大釜滑動式挑線杆,能使縫紉之線日平整結實與美觀。

採用簡易標數盤旋轉式之縫日調節器,能使縫日之大小更易控制,迴縫時僅須將過針一壓即可。

The pole projecting makes it easily to apply your superior technic for sewing small parts and special shaped type material.

Special rotary, horizontal hook and piston-type. Take-up lever applied to these machine. You can sew smoothly and easily with fine finishing.

The simple number dish and rotary stitch regulator make the needle stitch under controlled easily, quick back-stitch by push the back-stitch plate.

用途及規格 / USAGE AND SPECIFICATIONS

用於：馬鞋、運動鞋、工作鞋、休閒鞋、海綿鞋、嬰兒鞋、高級皮革鞋類縫製,備圓輪式與平押式押脚兩種,平押式押脚可用於帽子及假髮車縫。

最高縫速：每分鐘2,000針

最大縫日：4.0mm

針：DPX5

Ideal for boots shoes, work shoes, leisure shoes, foam rubber sole pads, babies shoes and high quality leather shoes. Ready for roller type & presser foot. Presser foot for stitching hat & hairpiece.

Max. Sewing Speed: 2,000 S. P. M.

Max. Stitch Length: 4.0mm

Needle System: DPX5

特點 / FEATURES

自小配件與細微材料之縫製迄由線形之縫紉,本機系統使您優越縫製技術威力充分發揮之高頭車。

採用全迴轉水平式大釜滑動式挑線杆,能使縫紉之線日平整結實與美觀。

採用簡易標數盤旋轉式之縫日調節器,能使縫日之大小更易控制,迴縫時僅須將過針一壓即可。

The pole projecting makes it easily to apply your superior technic for sewing small parts and special shaped type material.

Special rotary, horizontal hook and piston-type. Take-up lever applied to these machine. You can sew smoothly and easily with fine finishing.

The simple number dish and rotary stitch regulator make the needle stitch under controlled easily, quick back-stitch by push the back-stitch plate.

用途及規格 / USAGE AND SPECIFICATIONS

用於：馬鞋、運動鞋、工作鞋、休閒鞋、海綿鞋、嬰兒鞋、高級皮革鞋類縫製,備圓輪式與平押式押脚兩種,平押式押脚可用於帽子及假髮車縫。

最高縫速：每分鐘2,000針

最大縫日：4.0mm

針：DPX5

Ideal for boots shoes, work shoes, leisure shoes, foam rubber sole pads, babies shoes and high quality leather shoes. Ready for roller type & presser foot. Presser foot for stitching hat & hairpiece.

Max. Sewing Speed: 2,000 S. P. M.

Max. Stitch Length: 4.0mm

Needle System: DPX5

WA-840-P

Double Needle, Postbed Sewing Machine (COVER LIFT)

(LARGE HOOK AVAILABLE)

雙針高頭車(掀蓋式)

(可選配大旋梭)

