

WA-335-A

Sage Needle Cylinder Bed With Union Feed
(FOR BINDING USE)

單針總合送筒型(滾邊專用)

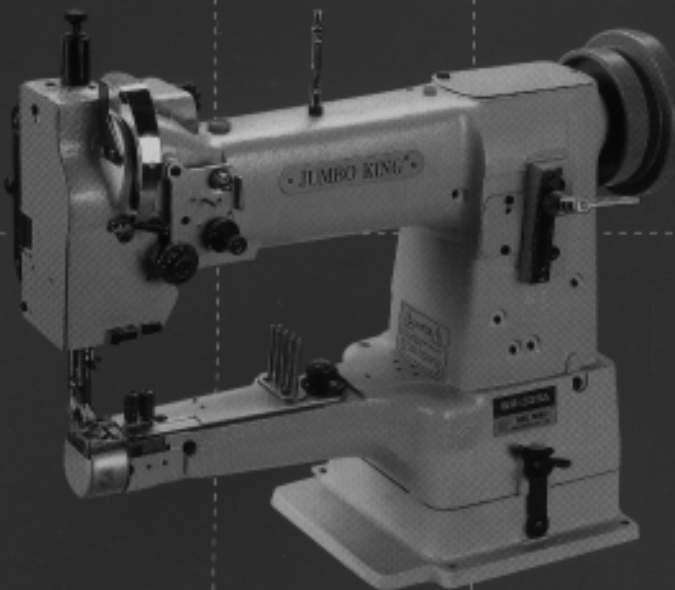

特點 / FEATURES

綜合送料,運轉肅靜,不拘材料表面之平滑或粗糙不平整,在縫製時皆很穩定。當幾層皮料加在一起縫製時,內層也不會移動。

縫製鞋子滾邊,凹凸,轉角等形狀時較穩定,可節省成本和時間。

新型針柱座,加一固定座,在縫製時比較穩定,減少斷針及斷線,並可縫製較整齊美觀的線路。

圓筒直徑46mm。

No matter the material's surface is either smooth or rough. It can sew steadily.

The inner layer won't move, even several leathers are sewed together.

By steadily hemming shoes and stitching the concave, convex corner, you can spare a lot of costs and time.

The needle clamp with an extra setting plate let you sew anything stably, several leather are sewn together and ensures less discrepancy in stitching.

Diameter of cylinder-bed is 46mm.

用途及規格/USAGE AND SPECIFICATIONS

用於: 鞋業滾邊、皮包滾邊、皮帶滾邊、皮包的合縫成型及筒狀物品之包邊。

最高縫速: 每分鐘2,000針

最大縫目: 5.5mm

針: DPX17

It is developed for hemming shoes, purse, belt for sewing bag, sofa and for shaping sport apparatus.

Max. Sewing Speed: 2,000 S. P. M.

Max. Stitch Length: 5.5mm

Needle System: DPX17

特點 / FEATURES

綜合送料,運轉肅靜,不拘材料表面之平滑或粗糙不平整,在縫製時皆很穩定。當幾層皮料加在一起縫製時,內層也不會移動。

縫製鞋子滾邊,凹凸,轉角等形狀時較穩定,可節省成本和時間。

新型針柱座,加一固定座,在縫製時比較穩定,減少斷針及斷線,並可縫製較整齊美觀的線路。

圓筒直徑46mm。

No matter the material's surface is either smooth or rough. It can sew steadily.

The inner layer won't move, even several leathers are sewed together.

By steadily hemming shoes and stitching the concave, convex corner, you can spare a lot of costs and time.

The needle clamp with an extra setting plate let you sew anything stably, several leather are sewn together and ensures less discrepancy in stitching.

Diameter of cylinder-bed is 46mm.

用途及規格/USAGE AND SPECIFICATIONS

用於: 鞋業滾邊、皮包滾邊、皮帶滾邊、皮包的合縫成型及筒狀物品之包邊。

最高縫速: 每分鐘2,000針

最大縫目: 5.5mm

針: DPX17

It is developed for hemming shoes, purse, belt for sewing bag, sofa and for shaping sport apparatus.

Max. Sewing Speed: 2,000 S. P. M.

Max. Stitch Length: 5.5mm

Needle System: DPX17

WA-335-B

Sage Needle Cylinder Bed With Union Feed
(FOR NORMAL USE)

單針總合送筒型(一般車縫)

